

DO NOT SCALE DRAWING

REVISION

A INITIAL DRAWING 21.9.15

Part Number	ØA	B Nom	C Max	D Nom	E Min	F Length
M2 6 PSA2MC S100	M2-0.4	4.0	1.3	0.5	0.5	6.0
M2 12 PSA2MC S100						12.0
M2.5 6 PSA2MC S100	M2.5-0.45	5.0	1.5	0.6	0.6	6.0
M2.5 12 PSA2MC S100						12.0
M2.5 16 PSA2MC S100						16.0
M3 6 PSA2MC S100	M3-0.5	6.0	1.8	0.8	0.7	6.0
M3 8 PSA2MC S100						8.0
M3 10 PSA2MC S100						10.0
M3 12 PSA2MC S100						12.0
M3 16 PSA2MC S100						16.0
M3 20 PSA2MC S100						20.0
M3 25 PSA2MC S100	25.0					
M3 30 PSA2MC S100	30.0					
M4 6 PSA2MC S100	M4-0.7	8.0	2.4	1.2	1.0	6.0
M4 10 PSA2MC S100						10.0
M4 12 PSA2MC S100						12.0
M4 16 PSA2MC S100						16.0
M4 20 PSA2MC S100						20.0
M4 25 PSA2MC S100						25.0
M4 30 PSA2MC S100						30.0
M4 40 PSA2MC S100	40.0					
M4 50 PSA2MC S100	50.0					
M5 12 PSA2MC S100	M5-0.8	10.0	5.7	1.2	1.2	12.0
M5 16 PSA2MC S100						16.0
M6 12 PSA2MC S100	M6-1.0	12.0	3.6	1.6	1.4	12.0
M6 16 PSA2MC S100						16.0
M6 25 PSA2MC S100						25.0

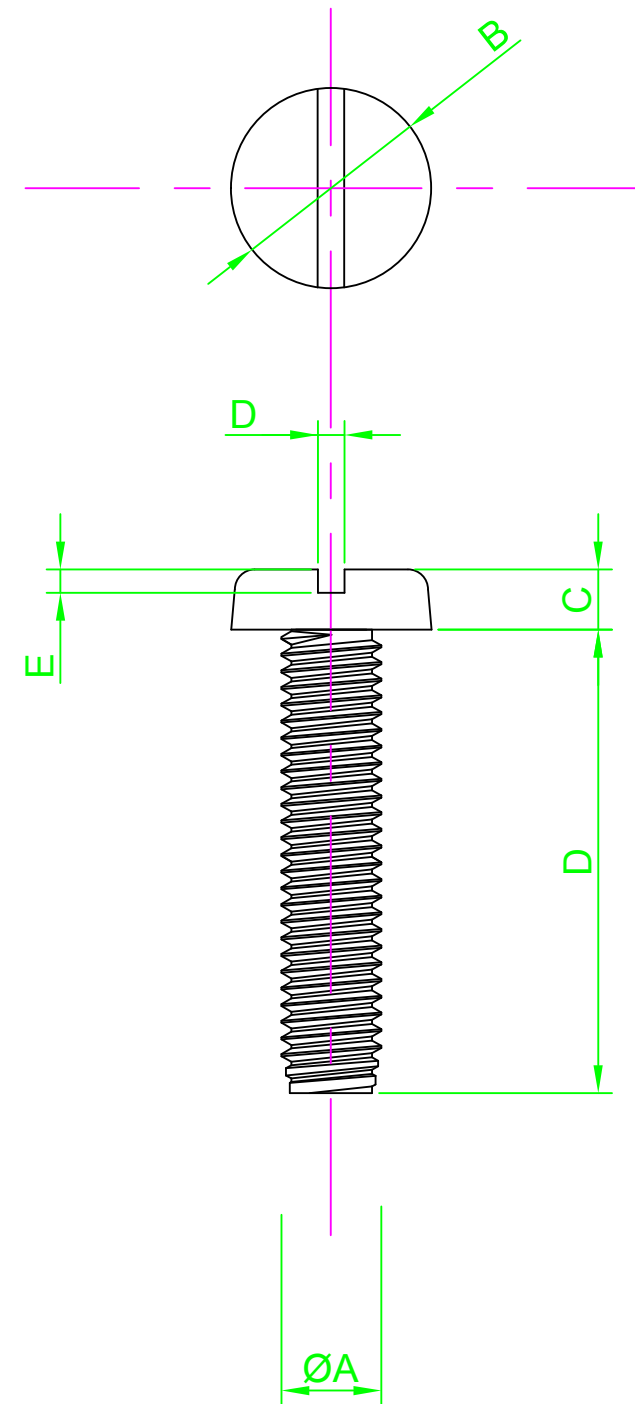

NOTES:
M2 & M2.5 Sizes not shown in DIN 85



DESIGN RIGHT. TR FASTENINGS LTD, 2003
UNDER NO CIRCUMSTANCES MUST THIS
DRAWING BE COPIED OR DISCLOSED
WITHOUT FIRST OBTAINING WRITTEN
AUTHORITY.

UNLESS OTHERWISE SPECIFIED:
DIMENSIONS ARE IN MM (MILLIMETERS).
SURFACE FINISH:
TOLERANCES: DIN 85

	NAME	DATE
DRAWN	Darryl Wilson	21.09.15
CHK'D		
APPVD		

MATERIAL:
Stainless Steel A2

HEAT TREATMENT:
N/A

FINISH:
Self Finish

TITLE:
Slotted Pan Head Machine Screw DIN 85

CUSTOMER PART NUMBER:
N/A

DRAWING NUMBER:
TR32PSA2MCS100

A4