NI-9853

2022-07-06



Contents

Overview.....	3
Safety Guidelines.....	3
Safety Guidelines for Hazardous Locations.....	3
EMC Guidelines.....	5
Cable Requirements for EMC Compliance.....	5
Wiring the NI-9853.....	6
CAN Bus Topology and Termination.....	7
Connecting a CAN Bus to the NI-9853.....	8
Cabling Requirements for the NI 9853.....	8
Cable Specifications.....	8
Termination Resistors.....	9
Cable Lengths.....	9
Number of CAN Nodes.....	9
NI-9853 Hardware Overview.....	9
NI-9853 Specifications.....	10
High-Speed CAN Characteristics.....	10
Power Requirements.....	11
Physical Characteristics.....	11
Safety.....	11
Hazardous Locations.....	12
Safety and Hazardous Locations Standards.....	12
Electromagnetic Compatibility.....	13
CE Compliance.....	13
Online Product Certification.....	14
Shock and Vibration.....	14
Environmental.....	14
Environmental Management.....	15
Waste Electrical and Electronic Equipment (WEEE).....	15
电子信息产品污染控制管理办法(中国 RoHS).....	15
Worldwide Support and Services.....	15

Overview

This document explains how to connect to the NI-9853.

The NI-9853 module requires the latest NI 985x software to be installed. The latest version of the NI 985x software is at ni.com/downloads.



Note Before you begin, complete the software and hardware installation procedures in your chassis documentation.



Note The guidelines in this document are specific to the NI-9853. The other components in the system might not meet the same safety ratings. Refer to the documentation for each component in the system to determine the safety and EMC ratings for the entire system.

Safety Guidelines

Operate the NI-9853 only as described in this document.

Hot Surface This icon denotes that the component may be hot. Touching this component may result in bodily injury.



Caution Do not operate the NI-9853 in a manner not specified in this document. Product misuse can result in a hazard. You can compromise the safety protection built into the product if the product is damaged in any way. If the product is damaged, return it to NI for repair.

Safety Guidelines for Hazardous Locations

The NI-9853 is suitable for use in Class I, Division 2, Groups A, B, C, D, T4 hazardous locations; Class I, Zone 2, AEx nA IIC T4 and Ex nA IIC T4 hazardous locations; and nonhazardous locations only. Follow these guidelines if you are installing the

NI-9853 in a potentially explosive environment. Not following these guidelines may result in serious injury or death.



Caution Do not disconnect I/O-side wires or connectors unless power has been switched off or the area is known to be nonhazardous.



Caution Do not remove modules unless power has been switched off or the area is known to be nonhazardous.



Caution Substitution of components may impair suitability for Class I, Division 2.



Caution For Division 2 and Zone 2 applications, install the system in an enclosure rated to at least IP54 as defined by IEC/EN 60079-15.



Caution For Zone 2 applications, install a protection device between the CAN signals and the NI-9853 CAN pins. The device must prevent the CAN Port-to-COM voltage from exceeding 55 V if there is a transient overvoltage condition.

Special Conditions for Hazardous Locations Use in Europe and Internationally

The NI-9853 has been evaluated as Ex nA IIC T4 Gc equipment under DEMKO Certificate No. 03 ATEX 0324020X and is IECEx 14.0089X certified. Each NI-9853 is marked Ⓜ II 3G and is suitable for use in Zone 2 hazardous locations, in ambient temperatures of $-40\text{ °C} \leq T_a \leq -70\text{ °C}$. If you are using the NI-9853 in Gas Group IIC hazardous locations, you must use the device in an NI chassis that has been evaluated as Ex nC IIC T4, Ex IIC T4, Ex nA IIC T4, or Ex nL IIC T4 equipment.



Caution You must make sure that transient disturbances do not exceed 140% of the rated voltage.



Caution The system shall only be used in an area of not more than Pollution Degree 2, as defined in IEC 60664-1.



Caution The system shall be mounted in an ATEX/IECEx-certified enclosure with a minimum ingress protection rating of at least IP54 as defined in IEC/EN 60079-15.



Caution The enclosure must have a door or cover accessible only by the use of a tool.

EMC Guidelines

This product was tested and complies with the regulatory requirements and limits for electromagnetic compatibility (EMC) stated in the product specifications. These requirements and limits provide reasonable protection against harmful interference when the product is operated in the intended operational electromagnetic environment.

This product is intended for use in industrial locations. However, harmful interference may occur in some installations, when the product is connected to a peripheral device or test object, or if the product is used in residential areas. To minimize interference with radio and television reception and prevent unacceptable performance degradation, install and use this product in strict accordance with the instructions in the product documentation.

Furthermore, any changes or modifications to the product not expressly approved by NI could void your authority to operate it under your local regulatory rules.



Notice To ensure the specified EMC performance for the NI-9853, you must install clamp-on ferrite beads (NI part number 711849-01) in accordance with the product installation instructions. Refer to the NI-9853 product page on ni.com for purchasing information about clamp-on ferrite beads.

Cable Requirements for EMC Compliance

Select and install cables for the NI-9853 in accordance with the following requirements:

- Install a clamp-on ferrite bead (NI part number 711849-01) on each end of the cable for each channel that you are connecting to on the NI-9853.
- Clamp-on ferrites must be connected to the cable as close to the module as possible with a full turn as shown in the following figure. Placing the ferrite elsewhere on the cable noticeably impairs its effectiveness.

Figure 1. Installing a Ferrite

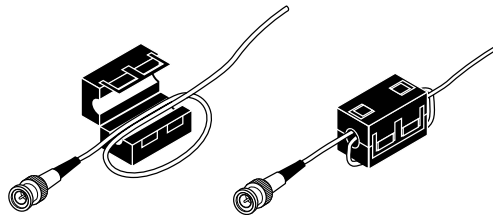

Wiring the NI-9853

The NI-9853 has two 9-pin male D-Sub connectors that provide connections to a CAN bus. Each port on the NI-9853 has pins for CAN_H and CAN_L, to which you connect the CAN bus signals. Connect these signals using twisted-pair cable. Each port has two common pins (COM) that are internally connected to the module's isolated reference and serve as the reference ground for CAN_H and CAN_L. You can connect the CAN bus reference ground (sometimes referred to as CAN_V-) to one or both COM pins. The port also has an optional shield pin, SHLD, that you can connect to a shielded CAN cable. Connecting SHLD may improve signal integrity and EMC performance in a noisy environment.

CAN0 of the NI-9853 is internally powered, and therefore requires no external power supply. CAN1 requires an external power supply of +8 to +25 V to operate. Supply power to the V_{SUP} pin of CAN1 from the CAN bus.



Note Although CAN0 of the NI-9853 does not require an external power supply to operate, it can be connected to a powered CAN bus without being damaged.

Pinouts for CAN0 and CAN1 of the NI-9853 are listed in Tables 1 and 2. Table 4 lists recommended termination resistor values.

Connector	Pin	Signal
	1	No Connection (NC)
	2	CAN_L
	3	COM
	4	NC
	5	SHLD
	6	COM
	7	CAN_H
	8	NC
	9	NC

Table 1. Pin Assignments for CAN0

Connector	Pin	Signal
	1	No Connection (NC)
	2	CAN_L
	3	COM
	4	NC
	5	SHLD
	6	COM
	7	CAN_H
	8	NC
	9	V _{SUP}

Table 2. Pin Assignments for CAN1

CAN Bus Topology and Termination

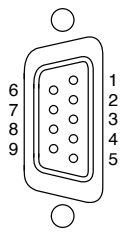
A CAN bus consists of two or more CAN nodes cabled together. The CAN_H and CAN_L pins of each node are connected to the main CAN bus cable through a short connection known as a “stub.” The pair of signal wires, CAN_H and CAN_L, constitutes a transmission line. If the transmission line is not terminated, each signal change on the bus causes reflections that may cause communication errors. Because the CAN bus is bidirectional, both ends of the cable must be terminated.

However, this requirement does not mean that every node on the bus should have a termination resistor; only the two nodes at the far end of the cable should have termination resistors.

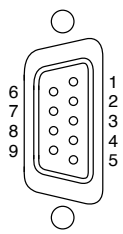
Figure 1 shows a simplified diagram of a CAN bus with multiple CAN nodes and proper termination resistor (R_t) locations.

Figure 2. CAN Bus Topology and Termination Resistor Locations

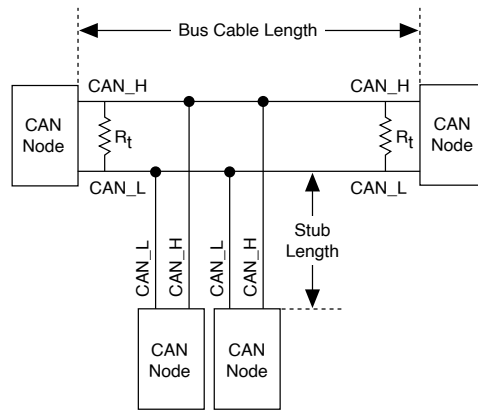

Connecting a CAN Bus to the NI-9853

You can connect each port of the NI-9853 to any location on a CAN bus. Figure 2 shows one example of connecting CAN0 of the NI-9853 directly to one CAN node, and CAN1 directly to another CAN node. CAN1 requires an external power supply on the CAN bus.

Figure 3. Connecting Both Ports of the NI-9853 to CAN Buses



Cable Specifications

Cables should meet the physical medium requirements specified in ISO 11898, shown in the following table. Belden cable (3084A) meets all these requirements and should be suitable for most applications.

Characteristic	Value
Impedance	95 Ω min,

Characteristic	Value
	120 Ω nominal, 140 Ω max
Length-related resistance	70 m Ω /m nominal
Specific line delay	5 ns/m nominal

Table 3. ISO 11898 Specifications for Characteristics of a CAN_H and CAN_L Pair of Wires

Termination Resistors

The termination resistors (R_t) should match the nominal impedance of the CAN cable and therefore comply with the values in the following table.

Characteristic	Value	Condition
Termination resistor, R_t	100 Ω min, 120 Ω nominal, 130 Ω max	Minimum power dissipation: 220 mW

Table 4. Termination Resistor Specification

Cable Lengths

The cabling characteristics and desired bit transmission rates affect the allowable cable length. You can find detailed cable length recommendations in the ISO 11898, CiA DS 102, and DeviceNet specifications.

ISO 11898 specifies 40 m total cable length with a maximum stub length of 0.3 m for a bit rate of 1 Mb/s. The ISO 11898 specification says that significantly longer cable lengths may be allowed at lower bit rates, but you should analyze each node for signal integrity problems.

Number of CAN Nodes

The maximum number of nodes depends on the electrical characteristics of the nodes on the network. If all nodes meet the ISO 11898 requirements, you can connect at least 30 nodes to the bus. You can connect higher numbers of nodes if the nodes' electrical characteristics do not degrade signal quality below ISO 11898 signal level specifications.

The NI-9853 electrical characteristics allow at least 110 CAN ports on a network.

NI-9853 Hardware Overview

The NI-9853 has two full-featured, independent CAN ports that are isolated from each other, and from the other modules in the system. Each port on the NI-9853 has a Philips SJA1000 controller that is CAN 2.0B-compatible and fully supports both 11-bit and 29-bit identifiers. The port also has a Philips TJA 1041 High-Speed CAN transceiver that is fully compatible with the ISO 11898 standard and supports baud rates up to 1 Mbps.

Figure 4. NI-9853 Hardware Overview



NI-9853 Specifications

The following specifications are typical for the range -40 °C to 70 °C unless otherwise noted.

High-Speed CAN Characteristics

Transceiver	Philips TJA 1041
Max baud rate	1 Mbps
CAN_H, CAN_L bus lines voltage	-27 to +40 VDC
Supply voltage range (V_{SUP})	
CAN1	+9 to +30 VDC
CAN0	N/A
MTBF	1,816,913 hours at 25 °C; Bellcore Issue 6, Method 1, Case 3, Limited Part Stress Method



Note Contact NI for Bellcore MTBF specifications at other temperatures or for MIL-HDBK-217F specifications.

Power Requirements

Power consumption from chassis

Active Mode

Transmitting 625 mW max

Receiving 400 mW max

Sleep mode 25 μ W max

Thermal dissipation (at 70 °C)

Active mode 1 W max

Sleep mode 250 mW max

Physical Characteristics

To clean the module, wipe it with a dry towel.

Weight	Approx. 144 g (5.0 oz)
--------	------------------------

Safety

Connect only voltages that are within the following limits:

Maximum Voltage^[1]

Port-to-COM -27 to +40 VDC max, Measurement Category I

Isolation

Port-to-port

Continuous 60 VDC, Measurement Category I up to 5,000 m altitude

Withstand	500 V _{rms} , verified by a 5 s dielectric withstand test
-----------	--

Port-to-earth ground

Continuous	60 VDC, Measurement Category I up to 5,000 m altitude
------------	---

Withstand	500 V _{rms} , verified by a 5 s dielectric withstand test
-----------	--

Measurement Category I is for measurements performed on circuits not directly connected to the electrical distribution system referred to as **MAINS** voltage. MAINS is a hazardous live electrical supply system that powers equipment. This category is for measurements of voltages from specially protected secondary circuits. Such voltage measurements include signal levels, special equipment, limited-energy parts of equipment, circuits powered by regulated low-voltage sources, and electronics.



Note Do not connect the NI-9853 to signals or use for measurements within Measurement Categories II, III, or IV.

¹ The maximum voltage that can be applied or output between any port or V_{SUP} terminal and a COM terminal without creating a safety hazard.

Hazardous Locations

U.S. (UL)	Class I, Division 2, Groups A, B, C, D, T4; Class I, Zone 2, AEx nA IIC T4
Canada (C-UL)	Class I, Division 2, Groups A, B, C, D, T4; Class I, Zone 2, Ex nA IIC T4
Europe (DEMKO)	Ex nA IIC T4 Gc

Safety and Hazardous Locations Standards

This product is designed to meet the requirements of the following electrical equipment safety standards for measurement, control, and laboratory use:

- IEC 61010-1, EN 61010-1
- UL 61010-1, CSA 61010-1

- EN 60079-0:2012, EN 60079-15:2010
- IEC 60079-0: Ed 6, IEC 60079-15; Ed 4
- UL 60079-0; Ed 5, UL 60079-15; Ed 3
- CSA 60079-0:2011, CSA 60079-15:2012



Note For UL and other safety certifications, refer to the product label or the [Online Product Certification](#) section.

Electromagnetic Compatibility

This product meets the requirements of the following EMC standards for sensitive electrical equipment for measurement, control, and laboratory use:

- EN 61326-2-1 (IEC 61326-2-1): Class A emissions; Industrial immunity
- EN 55011 (CISPR 11): Group 1, Class A emissions
- AS/NZS CISPR 11: Group 1, Class A emissions
- FCC 47 CFR Part 15B: Class A emissions
- ICES-001: Class A emissions



Note In the United States (per FCC 47 CFR), Class A equipment is intended for use in commercial, light-industrial, and heavy-industrial locations. In Europe, Canada, Australia and New Zealand (per CISPR 11) Class A equipment is intended for use only in heavy-industrial locations.



Note Group 1 equipment (per CISPR 11) is any industrial, scientific, or medical equipment that does not intentionally generate radio frequency energy for the treatment of material or inspection/analysis purposes.



Note For EMC declarations and certifications, and additional information, refer to the [Online Product Certification](#) section.

CE Compliance

This product meets the essential requirements of applicable European Directives, as follows:

- 2014/35/EU; Low-Voltage Directive (safety)
- 2014/30/EU; Electromagnetic Compatibility Directive (EMC)
- 94/9/EC; Potentially Explosive Atmospheres (ATEX)

Online Product Certification

Refer to the product Declaration of Conformity (DoC) for additional regulatory compliance information. To obtain product certifications and the DoC for this product, visit ni.com/certification, search by model number or product line, and click the appropriate link in the Certification column.

Shock and Vibration

To meet these specifications, you must panel mount the system.

Operating vibration	
Random (IEC 60068-2-64)	5 g _{rms} , 10 Hz to 500 Hz
Sinusoidal (IEC 60068-2-6)	5 g, 10 Hz to 500 Hz
Operating shock (IEC 60068-2-27)	30 g, 11 ms half sine; 50 g, 3 ms half sine; 18 shocks at 6 orientations

Environmental

Refer to the manual for the chassis you are using for more information about meeting these specifications.

Operating temperature (IEC 60068-2-1, IEC 60068-2-2)	-40 °C to 70 °C
Storage temperature (IEC 60068-2-1, IEC 60068-2-2)	-40 °C to 85 °C
Ingress protection (with power plug attached)	IP 40

Operating humidity (IEC 60068-2-78)	10% RH to 90% RH, noncondensing
Storage humidity (IEC 60068-2-78)	5% RH to 95% RH, noncondensing
Pollution Degree	2
Maximum altitude	5,000 m

Indoor use only.

Environmental Management

NI is committed to designing and manufacturing products in an environmentally responsible manner. NI recognizes that eliminating certain hazardous substances from our products is beneficial to the environment and to NI customers.

For additional environmental information, refer to the **Minimize Our Environmental Impact** web page at ni.com/environment. This page contains the environmental regulations and directives with which NI complies, as well as other environmental information not included in this document.

Waste Electrical and Electronic Equipment (WEEE)

EU Customers At the end of the product life cycle, all NI products must be disposed of according to local laws and regulations. For more information about how to recycle NI products in your region, visit ni.com/environment/weee.

电子信息产品污染控制管理办法 (中国 RoHS)

中国客户 National Instruments 符合中国电子信息产品中限制使用某些有害物质指令(RoHS)。关于 National Instruments 中国 RoHS 合规性信息，请登录 ni.com/environment/rohs_china。(For information about China RoHS compliance, go to ni.com/environment/rohs_china.)

Worldwide Support and Services

The National Instruments website is your complete resource for technical support. At ni.com/support, you have access to everything from troubleshooting and application development self-help resources to email and phone assistance from NI Application Engineers.

Visit ni.com/services for NI Factory Installation Services, repairs, extended warranty, and other services.

Visit ni.com/register to register your National Instruments product. Product registration facilitates technical support and ensures that you receive important information updates from NI.

A Declaration of Conformity (DoC) is our claim of compliance with the Council of the European Communities using the manufacturer's declaration of conformity. This system affords the user protection for electromagnetic compatibility (EMC) and product safety. You can obtain the DoC for your product by visiting ni.com/certification. If your product supports calibration, you can obtain the calibration certificate for your product at ni.com/calibration.

National Instruments corporate headquarters is located at 11500 North Mopac Expressway, Austin, Texas, 78759-3504. National Instruments also has offices located around the world. For telephone support in the United States, create your service request at ni.com/support or dial 1 866 ASK MYNI (275 6964). For telephone support outside the United States, visit the **Worldwide Offices** section of ni.com/niglobal to access the branch office websites, which provide up-to-date contact information, support phone numbers, email addresses, and current events.