

DO NOT SCALE DRAWING

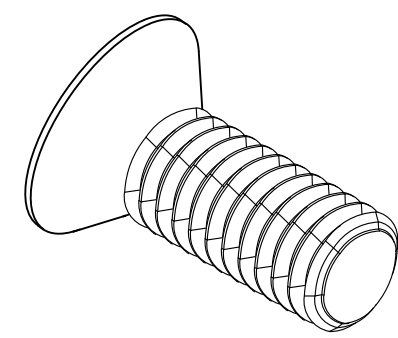
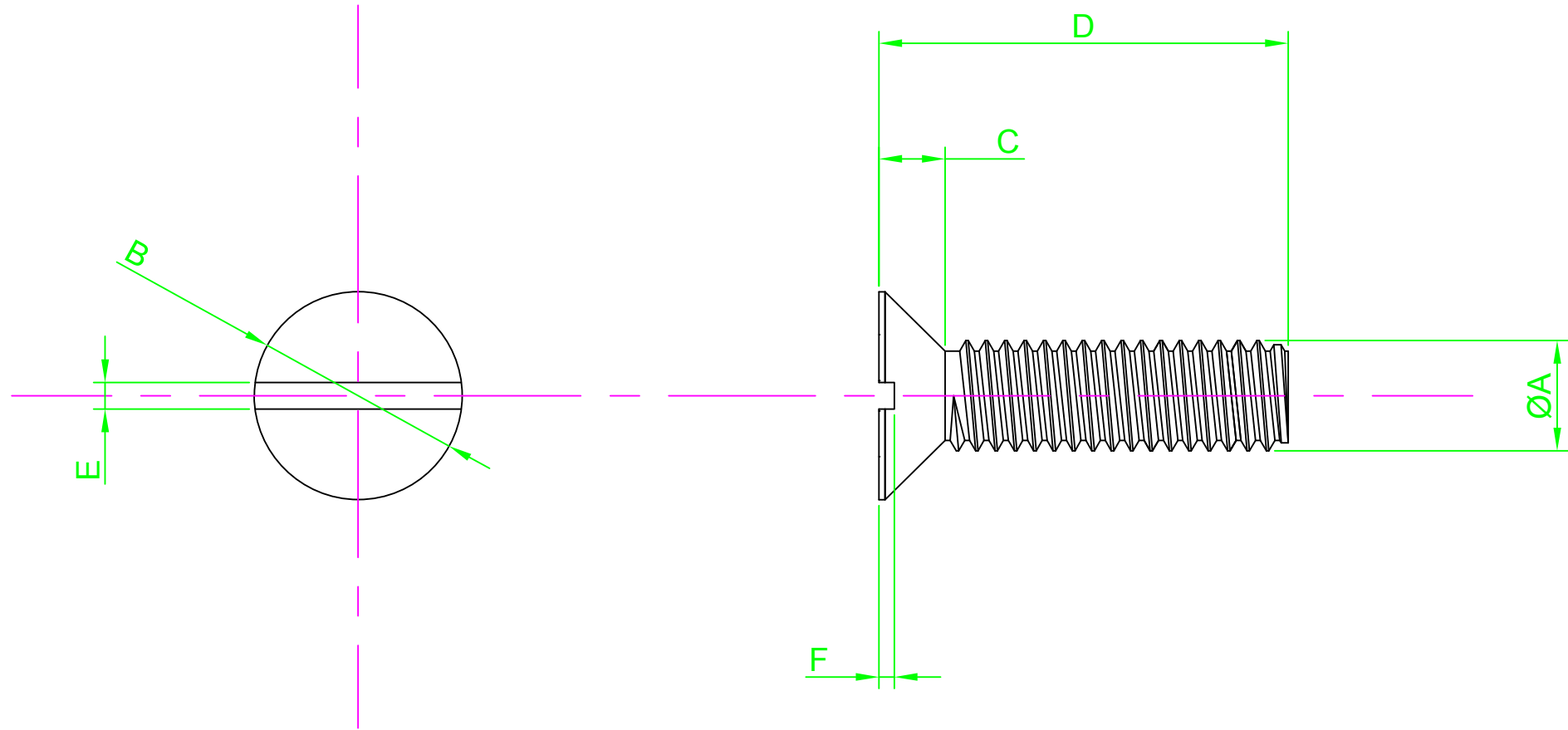

REVISION

A INITIAL DRAWING 21.9.15

Part Number	ØA	B Nom	C Max	D Length	E Nom	F Max
M3 6 KSA2MC S100	M3-0.5	5.6	1.65	6.0	0.8	1.0
M3 12 KSA2MC S100				12.0		
M3 20 KSA2MC S100				20.0		
M4 12 KSA2MC S100	M4-0.7	7.5	2.2	12.0	1.0	1.1
M4 20 KSA2MC S100				20.0		
M5 12 KSA2MC S100	M5-0.8	9.2	2.5	12.0	1.2	1.3
M6 25 KSA2MC S100	M6-1.0	11.0	3.0	25.0	1.6	1.6

NOTES:



UNLESS OTHERWISE SPECIFIED:
DIMENSIONS ARE IN MM (MILLIMETERS).
SURFACE FINISH:
TOLERANCES: DIN 963

MATERIAL:
Stainless Steel A2

TITLE:
Slotted Csk Head Machine Screw DIN 963

	NAME	DATE
DRAWN	Darryl Wilson	21.09.15
CHK'D		
APPVD		

HEAT TREATMENT:
N/A

DESIGN RIGHT. TR FASTENINGS LTD, 2003
UNDER NO CIRCUMSTANCES MUST THIS
DRAWING BE COPIED OR DISCLOSED
WITHOUT FIRST OBTAINING WRITTEN
AUTHORITY.

CUSTOMER PART NUMBER:
N/A

FINISH:
Self Finish

DRAWING NUMBER:
TR32KSA2MC

A4

